



ILEE® JULA MINI

CHARACTERISTICS

- ± 20 mrad angle of adjustment travel
- 0.24 mrad adjustment per click
- Colimated dot laser
- Laser in X-Y axis adjustable
- Two mounting options using either diameter $\varnothing 18$ g6 or diameter $\varnothing 16.4 +0/-0.1$ tolerance fit
- AR coated glass lens

APPLICATIONS

- Pointing
- Alignment
- Positioning
- Illumination

TECHNICAL DATA

Wave-length ¹⁾ nm	Optical output mW	Beam shape	Laser class ²⁾	Divergence ³⁾ mrad	Wavelength shift ⁴⁾ nm/°C	Output power stability ⁴⁾ % 25°C	Ripple noise 4–6VDC rms	Order number
● 635	<1	Dot	2	<0.5	0.25	<0.5	<1%	0177-33-92-01
● 635	3	Dot	3R	<0.5	0.25	<0.5	<1%	0177-34-92-01
○ 830	80	Dot	3B	<0.5	0.25	<0.5	<1%	0177-37-92-03
○ 830	80	Dot	3B	>33 ⁵⁾	0.25	<0.5	<1%	0177-37-92-02

¹⁾ other wavelengths on request ²⁾ EN/ISO 60825-1 ³⁾ @FWHM ⁴⁾ after warmup ⁵⁾ illuminator



DIMENSIONS (MM)

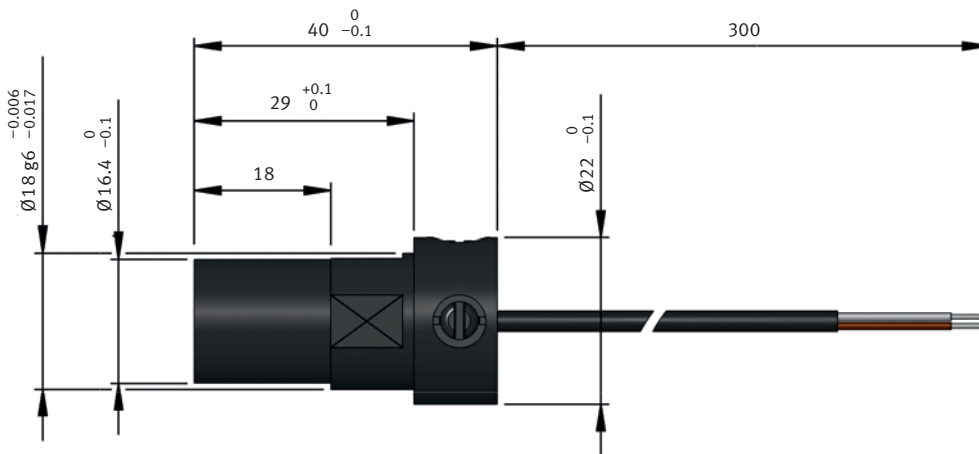

ELECTRICAL CONNECTION

VCC: Brown (+) Operating voltage: 3.3–5.5 VDC
GND: White (-)



Laser beams can cause damage to your eyes.
The user is responsible to observe the local safety regulations.

Mistakes and technical changes reserved.

Rheinmetall Air Defence AG

Birchstrasse 155 · 8050 Zurich · Switzerland · Phone +4144 316 2211
ilee.rad@rheinmetall.com · www.rheinmetall.com/ilee

