



# PRECISION FIREPOWER

## OERLIKON REVOLVER GUN® MK3 HLP

### AUTONOMOUS 35 MM AIR DEFENCE GUN ON HOOK-LIFTABLE PLATFORM (HLP)

This high precision 35 mm air defence gun with autonomous target engagement capability, integrated radar tracker and electro-optical sensor unit, is a powerful shooter capable for various kinds of missions.

The Oerlikon Revolver Gun® Mk3 can receive and process target data from 3D or 2D search radars or higher order control systems. The tracking radar's automatic search pattern makes target handover simple, fast and reliable. The integrated gun control computer manages target tracking and engagement and the electro-optical sensor unit enables visual target identification. Engagement supervision is performed from the engagement operator console in the control node.

The integrated 35 mm Oerlikon Revolver Cannon® provides superior fire power and accuracy. Combined with the Oerlikon Ahead® air burst ammunition the gun achieves a high effectiveness against both conventional and emerging air threats, including low, slow and small (LSS, UAV), rocket, artillery and mortar (RAM) and missile targets. The cannon and ammunition are fully qualified and in service. The Revolver Gun Mk3 is mounted on a standard (DIN 30722) hook-liftable platform (HLP) for easy transport and quick deployment in the field.

#### MAIN FEATURES

- Autonomous 35 mm air defence gun
- Effective combat range: up to 4,000 m
- C-RAM capability
- 35 mm Oerlikon Revolver Cannon®
- Nominal rate of fire: 1,000 rds/min
- Rapid single shot mode: 200 rds/min
- Ahead air burst ammunition
- Ready to fire ammunition: 252 rounds
- Remote charge and discharge function
- Quick charge and fire out function
- Ku-band tracking radar
- Modular electro-optical sensor unit
- Flexible target handover from 2D/3D search radars
- Automatic target acquisition and tracking
- Remote engagement supervision
- Fibre optical or radio (option) link to control node
- Rapid deployment with hook-liftable platform
- Simple handling and maintenance
- Integrated position locator and north direction finder
- No field alignment required
- Autonomous power supply
- Growth potential: Integrated AESA search radar

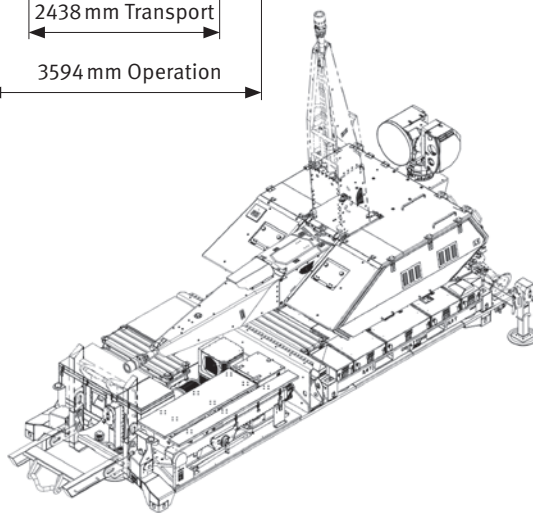
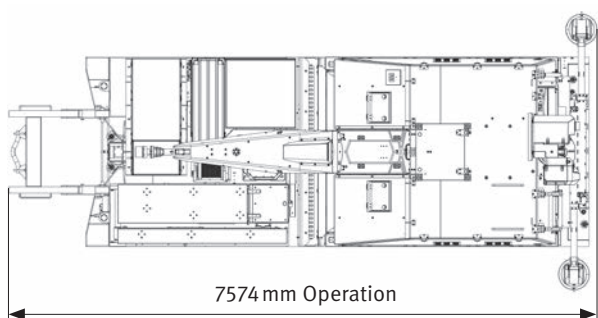
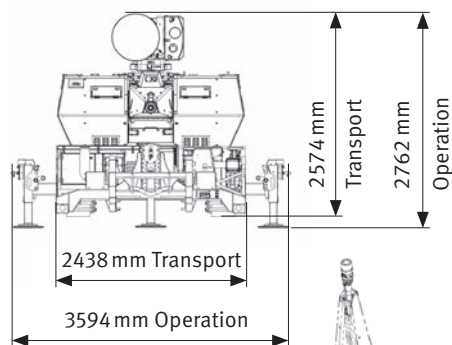
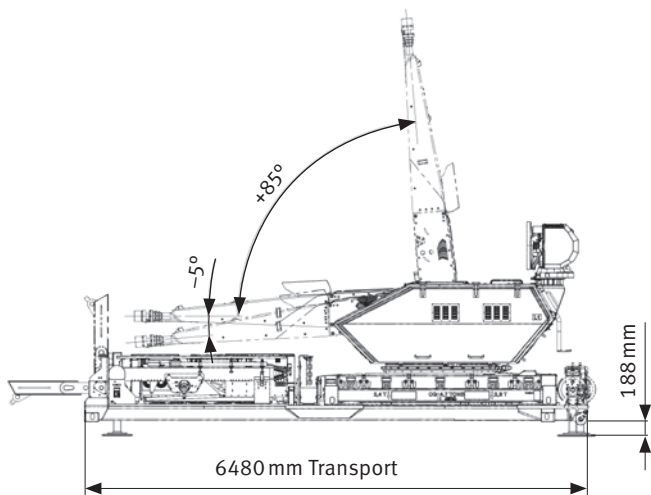

## TECHNICAL CHARACTERISTICS

### Cannon

Calibre	35 mm x 228
Nominal rate of fire	1,000 rounds/min
Rapid single shot	200 rounds/min
Mean muzzle velocity Ahead ( $V_0$ )	1,050 m/s
Mean muzzle velocity full calibre ( $V_0$ )	1,175 m/s
Length of cannon with muzzle brake	4,206 mm
Barrel length (90 cal.)	3,150 mm

### Ammunition

Types (NATO Code)	
Programmable	Ahead (KETF)
Standard full calibre	HEI-T, FAP, TP-T
Number of rounds ready to fire	252

### Gun turret

Weight of gun turret w/o ammunition	4,650 kg
Weight of gun turret with ammunition	5,100 kg
Swept radius (barrel 0°)	3,950 mm
Traverse arc	n x 360°
Elevation arc	-5° to +85°
Traverse speed	115°/s
Elevation speed	57°/s

### Tracking sensor unit

Tracking radar (TR)	Ku-band
Instrumented range	35 km
Update rate	50 Hz

### Electro-optical sensor package

TV camera	HD colour CMOS, 0.75°...37.5°
IR camera	Cooled MW, HD, 1.3°/4.6°/21.8°
Laser rangefinder	Eye safe class 1M, 6-10 Hz
Video tracker	Optimized for air targets
Sensor unit motion vs. gun turret	Az: ±150°, El: -15°...+85°

### Integrated search radar (growth potential)

Search radar type	3D AESA, S-band or X-band
Instrumented range	35 km
Spatial coverage	Az: 360°, El: -5°...+70°

### Operation

Unmanned during operation, set up with 2 operators  
Supervision from remote engagement operator console

### Gun on hook-liftable platform (HLP)

Weight of gun with hook-liftable platform	6,500 kg
Weight of gun with HLP and 504 rounds	7,400 kg

We reserve all rights in connection with this document. Data and descriptions have only an information value. Modifications are reserved. Oerlikon Revolver Gun®, Oerlikon Revolver Cannon® and Oerlikon Ahead® are registered trademarks of Rheinmetall Air Defence AG.

Rheinmetall Air Defence AG

Birchstrasse 155 · 8050 Zurich · Switzerland · info@rheinmetall-defence.com · www.rheinmetall.com