



WITHOUT **DELAY**

RHEINMETALL MSU 200/400

KEEP AIRCRAFT RUNNING ON TIME WITH THE
ONLY TURBINE-POWERED AIR START UNIT.

TAKING RESPONSIBILITY IN A CHANGING WORLD

 **RHEINMETALL**



Aircraft on-board auxiliary power units are designed to power aircraft systems on the ground. But they are not perfect and they also use costly on-board fuel.

A reliable external air-start system is one that avoids unnecessary financial losses while ensuring aircraft run on time. Overall, it is the best way to get started and the Rheinmetall MSU Air Start Unit (ASU) is the preferred solution by far.

Designed to be reliable and versatile, the Rheinmetall MSU

is powered by a gas turbine engine, unique in its class. Proven across the globe, the MSU is also remarkably easy to operate.

One of the Rheinmetall MSU's main advantages is its low total cost of ownership, thanks to its state-of-the-art design. Rheinmetall ASUs have a long service life (20+ years) and are virtually maintenance free. With a short runtime of only 6 minutes per start and no need for a cool-down phase, fuel consumption is minimised, which also benefits the environment.

The Rheinmetall MSU can run on Sustainable Aviation Fuel allowing you to significantly reduce carbon emissions.

↳ Did you know? 65% of the IATA's Net Zero CO2 emission reductions could be achieved by using Sustainable Aviation Fuel.

SERVICE IS THE NUMBER ONE PRIORITY

Rheinmetall prides itself on its superior customer service and rapid delivery of spare parts. To provide greater service, Rheinmetall offers a global distribution network with centres in three strategic locations: North America, Europe, and Asia.

Rheinmetall ASUs are compliant with all international standards (IATA, CE, AHM, SAE) and are compatible with all makes of aircraft which are started pneumatically, including:

- Airbus
- BAE
- Boeing
- Bombardier Aerospace
- Embraer
- Eurofighter Jagdflugzeug
- Fokker
- General Dynamics
- Ilyushin
- Lockheed
- McDonnell Douglas
- Northrop Grumman
- Suchoi
- Tupolev

FIELDING AROUND THE WORLD

More than 1,400 units sold to 300+ customers in 50 countries!



THE TECHNOLOGY IN DETAIL

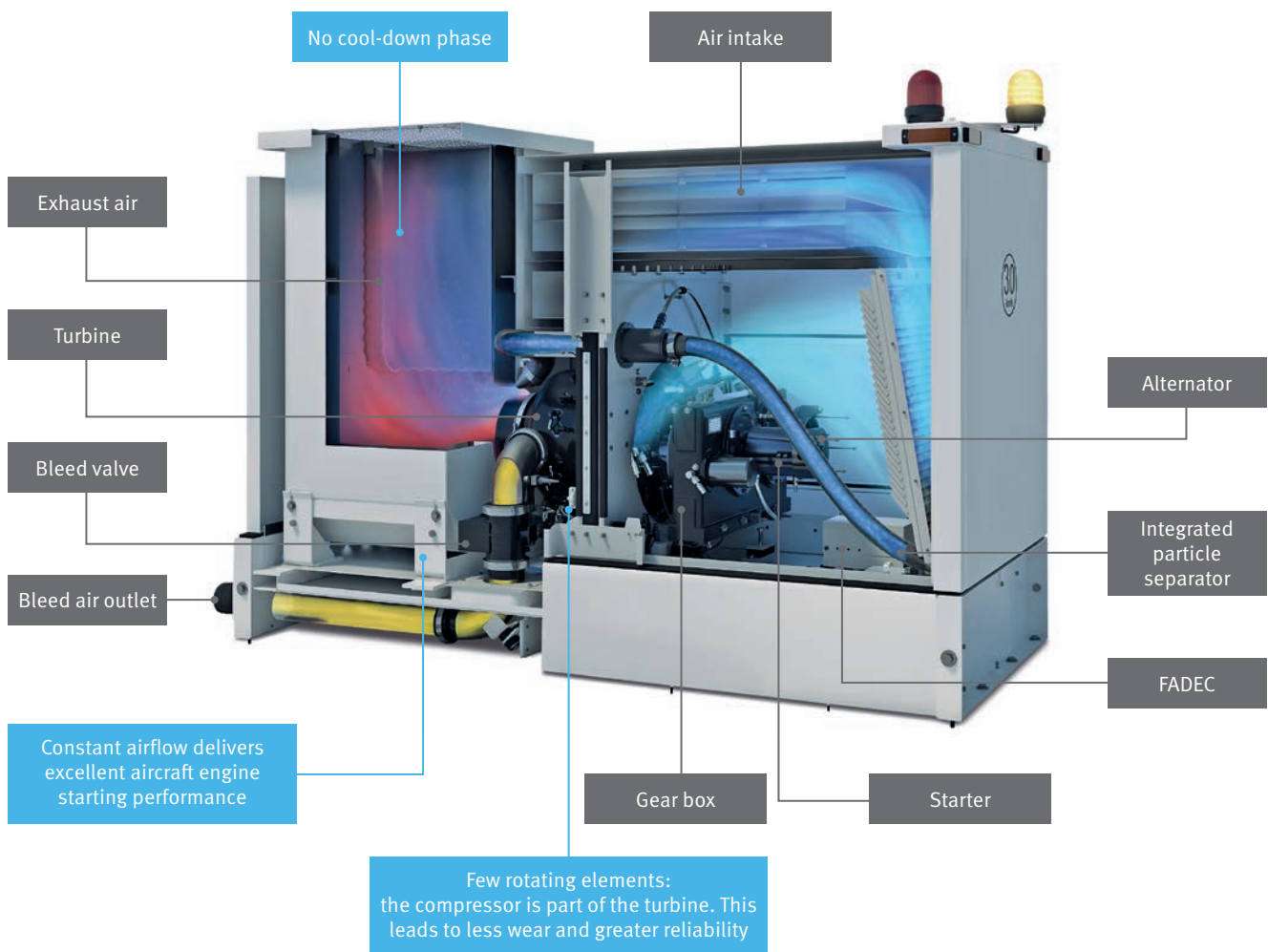

SYSTEM HIGHLIGHTS

A robust and reliable partner on the apron, Rheinmetall MSU offers unsurpassed features and impressive benefits.

- **Free choice of fuel:** Rheinmetall MSU runs on your choice of fuel. Jet fuel, diesel, any mix of the two or Sustainable Aviation Fuel (SAF).
 - ↳ Fuel up flexibly, anywhere, anytime.
 - ↳ Reduce your carbon footprint by using Sustainable Aviation Fuel.
- **Dual-function system:** Bleed air can be used for both the main engine start and environmental control system; the changeover takes place automatically.
 - ↳ Benefit from flexibility.
- **Multiple configurations:** Rheinmetall MSU can be installed on a trailer or vehicle, or used as a stationary system.
 - ↳ Mobilize a solution customized to your needs.
- **Compact size:** Rheinmetall MSU has a small footprint on the apron and in storage.
 - ↳ Take advantage from easy handling and operation.
 - ↳ Defence customers will find the unit easily airtransportable to deployed locations.
- **Proven cutting-edge technology:** Driven by high-performance Pratt & Whitney turbine engines, Rheinmetall MSU is a mark of quality since 1996.
 - ↳ Harness superior engine-starting performance.
- **Demonstrated efficiency in any climatic conditions:** Developed to handle ambient temperatures of -32°C to $+52^{\circ}\text{C}$ (-25.6°F to $+125.6^{\circ}\text{F}$).
 - ↳ Experience outstanding reliability, 24/7, 365 days a year.

EASY-TO-USE INTERFACE

The operator panel is intuitively designed, operation is safe, and instructions are easy to follow.

Get started in five easy steps:

1. Connect the bleed air hose to the aircraft.
Press ON to turn on the MSU.
2. A self-test is performed. The display reads "SELF-TEST O.K." once completed.
3. Press START to begin the short warm-up phase.
The START button starts flashing.
4. When the START button stays lit, the system is ready to deliver compressed air.
5. Press BLEED to initiate air flow and start the aircraft engine.



A MODEL FOR EVERY NEED

A compact design and a choice of configuration provide the flexibility to meet a variety of requirements.

MSU 200 – Rheinmetall's basic air start unit is available as a skid version (S), mounted on a trailer (T), or on a vehicle (V).

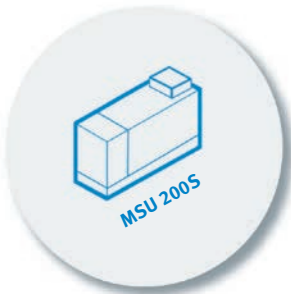

The skid version can be integrated with legacy equipment.

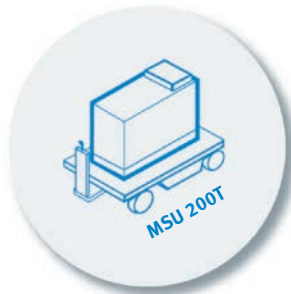

The trailer-mounted version can be manually moved into position.



The motorised version offers a ready-to-go, turnkey MSU solution, without any need for towing.

MSU 400 – Rheinmetall's two-unit model provide more power when needed (e.g. Boeing 777, Airbus A380); each unit can be operated individually. The MSU 400 is also available in skid (S), trailer (T), and vehicle (V) configurations.

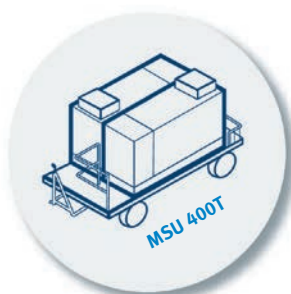
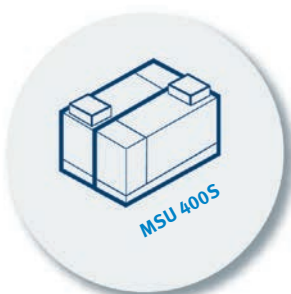

TECHNICAL DATA	MSU 200S	MSU 200T	MSU 200V	MSU 400T	MSU 400V
Nominal rating					
Bleed air output ¹⁾	204 ppm (1.54 kg/s)	204 ppm (1.54 kg/s)	204 ppm (1.54 kg/s)	408 ppm (3.08 kg/s)	408 ppm (3.08 kg/s)
Delivery pressure	56 psia (3.86 bar abs)				
Bleed air temperature	215°C (420°F)				
Weight and dimensions			MB Sprinter ²⁾	Isuzu chassis ²⁾	
Weight excluding fuel	1,180 kg (2,601 lbs)	1,623 kg (3,578 lbs)	3,570 kg (7,871 lbs)	3,365 kg (7,419 lbs)	5,750 kg (12,677 lbs)
Length	2.62 m (103.2 in)	4.30 m (169 in)	5.99 m (235.8 in)	5.70 m (227.6 in)	6.70 m (263.8 in)
Storage length (with tow bar in upright position)	–	3.32 m (136.6 in)	–	–	–
Width	0.9 m (35.4 in)	1.61 m (63.4 in)	2.04 m (90.3 in)	2.18 m (85.8 in)	2.18 m (85.8 in)
Height	1.6 m (63 in)	2.32 m (91.3 in)	2.50 m (98.4 in)	2.45 m (96.5 in)	2.74 m (107.9 in)
Environmental data					
Temperature	–32°C * (–25.6°F) to +52°C (125.6°F)				
Fuels	JET-A, Jet-A1, Jet-B, JP 4, JP 5, JP 8, F-34, F-35, F-37, F-40, F-44, F-54 AVTUR, AVTUR/FSII, Diesel DIN EN 590, DF1, DF2, mixes allowed				
Runs on Sustainable Aviation Fuel					
Noise level	85 ±2dB(A) at 7m (23ft) with full load	85 ±2dB(A) at 7m (23ft) with full load	85 ±2dB(A) at 7m (23ft) with full load	90 ±2dB(A) at 7m (23ft) with full load	90 ±2dB(A) at 7m (23ft) with full load

¹⁾ At 15°C ambient temperature, sea level

²⁾ Chassis availability depends on country and client requirements

All data are subject to change without notice.

MSU 200S

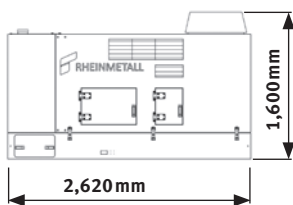

MSU 200T

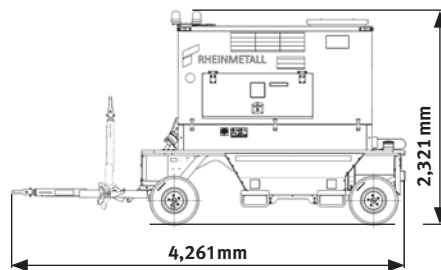

MSU 200V

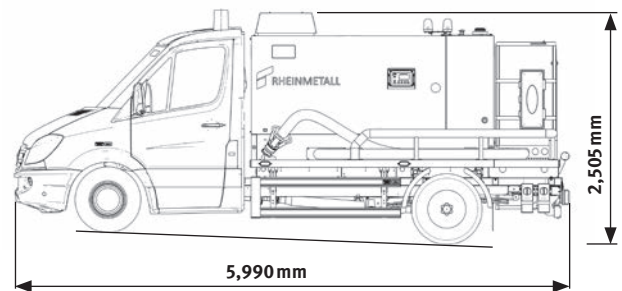

TECHNICAL DATA	MSU 200S	MSU 200T	MSU 200V	MSU 400T	MSU 400V
Air inlet		Particle separator with scavenge system			
Control system		Full Authority Digital Engine Control (FADEC)			
		Built-In Test Equipment (BITE)			
Operating modes and functions		Main Engine Start (MES)			
		Environmental Control System (ECS)			
		Automatic mode selection (MES/ECS)			
		No load restrictions in ECS mode			
Safety		Overspeed shut down			
		Exhaust gas overtemperature control			
		High oil temperature shutdown (override during MES)			
		Low oil pressure shutdown (override during MES)			
Panel functions		Multifunction display			
International standards		I.A.T.A. Regulations			
		CE Regulations			
		SAE Regulations			
Options (costs may vary)		Galvanised trailer (powder coated)			
		Jumpstart socket			
		Pull eye available in different diameters			
		MSU unit available in any RAL color			

All data subject to change without notice.

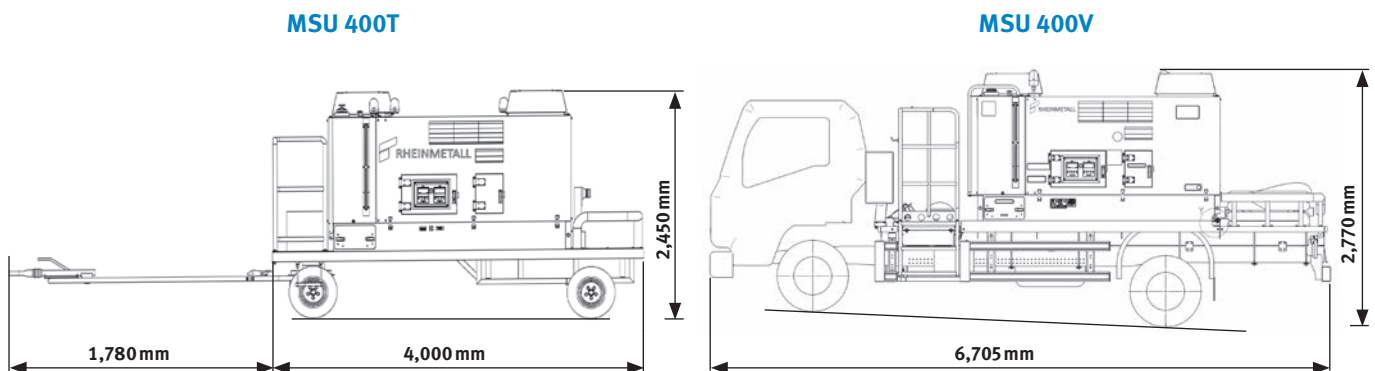

Rheinmetall also offers an air start unit with integrated ground power: **the MSU-GP 200T.**

For more information on Ground Support Equipment,
contact us at:

Rheinmetall Canada GSE

Phone: +1 450-542-5682

GSE@rheinmetall.ca

Rheinmetall Canada Inc.

Headquarters

225, boulevard du Séminaire Sud
Saint-Jean-sur-Richelieu (Québec) J3B 8E9
Canada

Ottawa Office

99 Metcalfe Street, Suite 304
Ottawa (Ontario) K1P 6L7
Canada

www.rheinmetall.ca