



# TRAILBLAZER

ARMoured VISION

PASSION FOR TECHNOLOGY.



**TRAILBLAZER improves driver and crew effectiveness by extending the field of view beyond the daylight spectrum, even in adverse weather, obscured or low-light conditions. Featuring very low-latency front and rear video camera units, it aids the driver in terrain negotiation, obstacle avoidance and route selection. Independent wide-angle situational awareness channel outputs give crew and commander a powerful surveillance and threat detection capability. GVA compliant, native digital and analogue variants make TRAILBLAZER easy to integrate.**



## KEY FEATURES

- Enhances operations in degraded visual environments
- Dual-band: high performance sensors and optics
- REUK Video fusion technology maximises DRI
- Conventional and/or networked video connectivity
- Driver and local situational awareness channels
- Extra-wide angle options
- Rugged dual wiper cleaning system
- Easy to integrate – GVA and DEF STAN 00-082 compliant

## APPLICATIONS

**TRAILBLAZER** is designed for hatches down driving in tracked and wheeled armoured vehicles. Other specialist vehicles such as engineering or special operations platforms can also benefit. The system can operate with single or dual camera configurations, providing support for both forward and reverse mobility.

The operator can select from a range of fields of view to support the operation: WIDE, DRIVING and SA (incl. ground), all presented flexibly as individual output channels, or via native picture-in-picture modes.



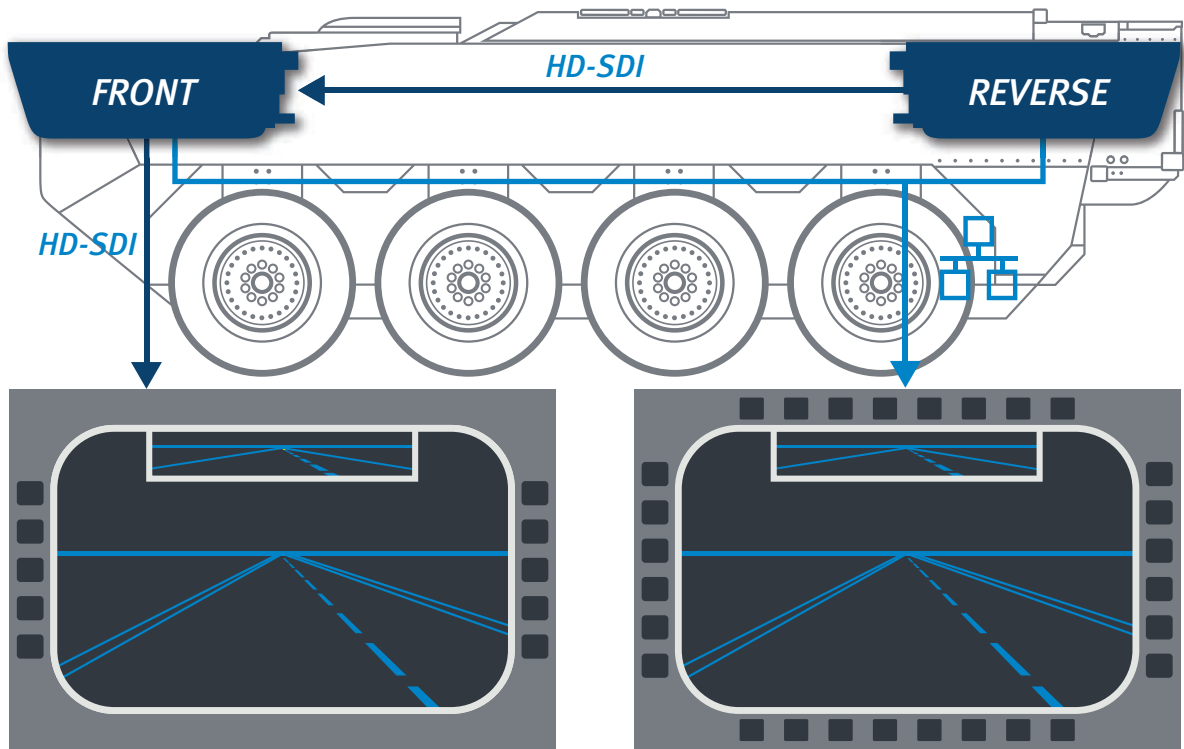

## NETWORKED VIDEO

DEF STAN00-082 VIVOE Ethernet interfaces make the system easy to integrate in a Generic Vehicle Architecture (GVA) system, and native HD-SDI interfaces or analogue video outputs provide a closed circuit output for conventional vetronics fit-out. The network output also provides other users with independent Situation Awareness (SA) fields of view, minimising the needs for separate SA sensors.

## FUSION

**TRAILBLAZER'S** Video Fusion algorithm by REUK, produces an optimum, composite image from the daylight and IR sensors. With significant performance advantages over traditional blending methods, the advanced multi-resolution solution boasts impressive features and can aid in spotting potential threats hidden from view.

## ACCESSORIES

### TRAILBLAZER Display Options

To support stand-alone and hybrid installations, REUK offers a range of optimised **TRAILBLAZER** displays; the Display and Control Unit (DUC) and Drivers Display Unit (DDU). These displays have been specifically designed for situations where the user needs to access digital video feeds, but where the space envelope is severely constrained, such as the driver compartment of modern armoured vehicles. They are available in a range of resolutions with a number of fixed function buttons and configurable buttons to deliver a flexible user interface, tailored to the specific requirements of each installation.

The **TRAILBLAZER** displays are fully hosted by the camera module and do not require any additional data or power connection to the vehicle to support stand-alone installation.



MODEL RANGE			
Features	DCU9	DCU7	DDU
Display diagonal resolution	9"	7"	8"
	1280 x 768	1920 x 1080	1280 x 768
Brightness	400 cd/m <sup>2</sup>	400 cd/m <sup>2</sup>	800 cd/m <sup>2</sup>
Contrast ratio	1000:1	800:1	1400:1
Viewing angles degrees	85/85/85/85	85/85/85/85	85/85/85/85
Latency	<20 ms	<20 ms	<20 ms
Weight	<2.5 kg	<2.0 kg	<2.0 kg
Dimensions (W x H x D) without connectors	250 x 150 x 35 mm	220 x 120 x 35 mm	310 x 126 x 28 mm
Qualifications	TRAILBLAZER DCU and DDU is qualified in accordance with UK DEF-STANs 00-035, 59-411, 61-500 and US MIL-STD-810, 461, 1275		

\* All specifications subject to change without notice

## VEHICLE INTEGRATION

Dedicated mounting assemblies are available to support vehicle specific integration. A protective cover provides additional mechanical protection and protection from solar radiation. This offers mounting points for add-on anti-IR

covers, optic covers or gratings offering protection against debris. REUK's experienced integration engineers can provide standard and customised solutions. Contact REUK sales for ordering information.



### HD180W MODEL SPECS

Daylight sensor (x2)	CMOS low light colour, 1920 x 1080@3.45 µm pitch, wavelength 350 – 1100 nm
Daylight FoV	180° horizontal
Device control interface	CAN bus (J1939), RS422, GVA (DEF STAN 23-009)
Video: Distribution output	DEF STAN 00-082
Latency	<40 ms
Image enhancement	Distortion correction, Adaptive contrast enhancement
Cleaning functions	Mechanical wiper x2
Weight	6.5 kg
Power consumption	<27 W
Dimensions (W x H x D) without connectors	270 x 130 x 160 mm



### HD240W MODEL SPECS

Daylight sensor (x3)	CMOS low light colour, 1920 x 1080@3.45 µm pitch, wavelength 350 – 1100 nm
Thermal sensor (x1)	Uncooled micro bolometer, 640 x 480@17 µm pitch, wavelength 8 – 14 µm
Daylight FoV	240° horizontal
Thermal FoV	68° horizontal
Device control interface	CAN bus (J1939), RS422, GVA (DEF STAN 23-009)
Video: Driver output	HD-SDI (720p50)
Video: Distribution output	DEF STAN 00-082
Latency	<40 ms
Image enhancement	Distortion correction, Adaptive contrast enhancement
Cleaning functions	Mechanical wiper x3
Weight	8.5 kg
Power consumption	<37 W
Dimensions (W x H x D) without connectors	298 x 118 x 192 mm





#### HD68 MODEL RANGE

Model Specs	HD68	HD68W	HD68W-IR
Daylight sensor	CMOS low light colour, 1920x1080@3.45 μm pitch, wavelength 350 – 1100 nm		N/A
Thermal sensor	Uncooled micro bolometer, 640x480@17 μm pitch, wavelength 8 – 14 μm		
Daylight FoV	68° horizontal		N/A
Thermal FoV	68° horizontal		
Device control interface	CAN bus (J1939), RS422, SNMP		
Video: Driver output	HD-SDI (720p50)		
Video: Distribution output	DEF STAN 00-082; HD-SDI (720p50)		
Latency	<40ms		
Image enhancement	Distortion correction, Adaptive contrast enhancement, Video fusion		
Cleaning functions	N/A	Dual optic mechanical wiper	Mechanical wiper
Weight	<2.8kg	<3.4kg	<3.4kg
Power consumption	<26W		
Dimensions (W x H x D) without connectors	160 x 80 x 140mm	210 x 80 x 170mm	



#### HD90 MODEL RANGE

Model Specs	HD90	HD90W	HD90W-IR
Daylight sensor	CMOS low light colour, 1920x1080@3.45 μm pitch, wavelength 350 – 1100 nm		N/A
Thermal sensor	Uncooled micro bolometer, 640x480@17 μm pitch, wavelength 8 – 14 μm		
Daylight FoV	90° horizontal		N/A
Thermal FoV	90° horizontal		
Device control interface	CAN bus (J1939), RS422, SNMP		
Video: Driver output	HD-SDI (720p50)		
Video: Distribution output	DEF STAN 00-082; HD-SDI (720p50)		
Latency	<40ms		
Image enhancement	Distortion correction, Adaptive contrast enhancement, Video fusion		
Cleaning functions	N/A	Dual optic mechanical wiper	Mechanical wiper
Weight	<3.2kg	<3.8kg	<3.8kg
Power consumption	<26W		
Dimensions (W x H x D) without connectors	183 x 84 x 154mm	234 x 90 x 189mm	

**Rheinmetall Electronics UK Ltd.**

**UK Office**

**Unit B The Apex**

St. Cross Business Park

Newport, Isle of Wight

PO30 5XW

[sales\\_reuk@rheinmetall.com](mailto:sales_reuk@rheinmetall.com)

Phone +44 1983 216600

**US Office**

**American Rheinmetall Systems LLC**

15 Morin St, Biddeford

ME 04005, USA

[reuk@rheinmetall-us.com](mailto:reuk@rheinmetall-us.com)