



CARACAL

AIR ASSAULT VEHICLE

War suitability – Easy-to-use technology with successful application in the UKR.

Technical superiority – Available as a 4x4 or 6x6 platform in different variants, with a towing capacity of up to 2 tonnes. Use of different types of armament.

Simplicity – The basic operability of the civilian Mercedes-Benz G-Class is retained. Only instruction in the military set-up kit and the all-wheel drive system is required.

Robustness – Chassis available on the market with additional optional ballistic and mine protection components in accordance with STANAG 4569.

Logistical availability – Easy spare parts procurement with access to MB Service network worldwide.

Modularity – The unique rail system of the ACS superstructure enables the user to retrofit the CARACAL system for specific missions, even in the field.

Command and control capability – C4I equipped for D-LBO.

Growth capability – The CARACAL can be configured according to customer requirements and therefore offers a high degree of modularity and adaptability.

MAIN FEATURES

- Exclusive co-operation between Rheinmetall, Mercedes-Benz and ACS
- Military standard chassis of the latest generation G-Class from Mercedes-Benz
- Lightweight and modular superstructures from ACS
- Transport of up to two vehicles in the CH-47F and CH-53K heavy transport helicopters
- Air transport capability as external load
- Integration of standard infantry weapons and ATGM weapons on ring mounts
- Large series availability
- Full life-cycle support over 20 years by Rheinmetall



TECHNICAL DATA

Dimensions

Length	4,735 mm (basic vehicle)
Width	1,810 mm
Height	1,850 mm

Weights

Vehicle weight	2,900 kg
Payload capacity	up to 2,000 kg
Weight air transport	up to 4,536 kg (CH-47F), up to 4,900 kg (CH-53K)

Performance

Max. road speed	130 km/h
Slope angle	60%
Lateral slope angle	30%
Wading depth	750 mm
Climbing ability	330 mm
Trench crossing	500 mm

Engine

Manufacturer	Mercedes-Benz
Kind	6-cylinder diesel engine/EURO3
Performance	249 PS
Torque	600 NM

Air transport

Aircraft CH-47F	1 vehicle with <4,536 kg, internal or external load
Aircraft CH-53K	1 vehicle with <4,900 kg, internal or external load
Aircraft	Air-portable with Boing C17, Lockheed Martin C-130, Embraer KC-390, Airbus A400M

Variants

Variant 1	Passenger transport vehicle with different roles
Variant 2	Ambulance vehicle
Variant 3	Group transport vehicle 6x6
Variant 4	Material transport vehicle 6x6

Protection

Ballistic protection	STANAG 4569; AEP-55 Vol.1 (Level 1 incl. FSP)
Mine protection	STANAG 4569; AEP-55 Vol.2 (Level 1 DM31)

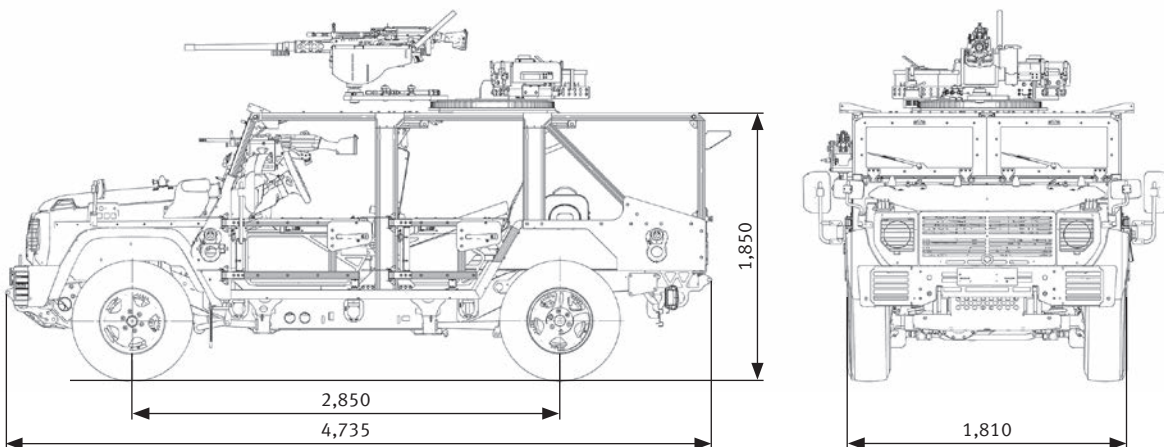

All dimensions in millimetres.

Rheinmetall Landsysteme GmbH

Heinrich-Ehrhardt-Strasse 2 · 29345 Unterlüss · Germany · sales-rls@rheinmetall.com · www.rheinmetall.com